

PD550 Single Inverter for Motor Control



High-power inverter integrated with brake chopper output.
Ideal for high power drive system applications.

John Deere Electronic Solutions has created a family of inverters designed to provide advanced control for AC motor applications. The product line covers a wide range of power levels (up to 300 KVA) and utilizes common motor control software for efficient control of IPM or induction motors.

The PD550 single inverter is based on high performance DSP real-time embedded software to support advanced features such as field-oriented control. The high-voltage, high-power modules are designed to work at maximum efficiency with complete monitoring capabilities to ensure control under all conditions. The thermal management system is liquid-cooled for robust and reliable performance over the life of the system.



PD550 Single Inverter

Dimensions

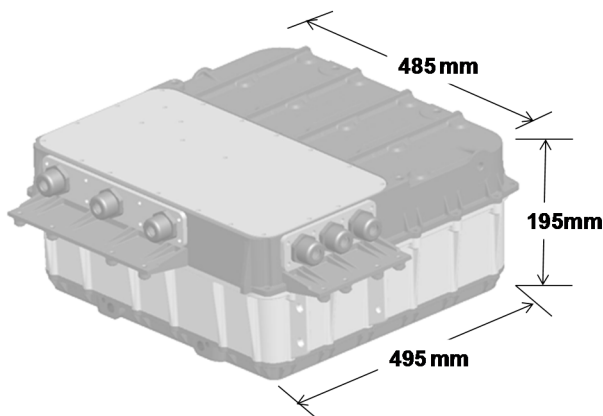

Features

- Compact and extremely rugged high-power AC motor inverters provide speed, torque, and voltage control
- Models rated from 80 KVA to 300 KVA
- Used in wide range of high-voltage DC bus systems (180 to 750 VDC systems)
- Sealed enclosure (IP67) liquid-cooled power section
- Tested to strict off-road vehicle standards for extreme environments including CISPR25 class 3 and SAE J1113-41 for EMC
- Meets applicable IEC 62477-1 component requirements
- External bus interface for system control
- Dual high-speed CAN
- Space vector and discontinuous PWM output voltage control
- High-performance AC field-oriented control
- Efficient control of induction or IPM machines

Preliminary Specifications

Output Power	300 KVA (700 V)
Weight	35 kg (dry, no coolant)
Current Rating	<ul style="list-style-type: none"> – 480 arms peak for 60 seconds (2.0 kHz PWM , 70°C cooling, 12 lpm) (assumes 320 arms operation for 240 second period, 20% duty cycle) – 400 arms continuous (2.0 kHz PWM, 70°C cooling, 12 lpm) (assumes no peak current operation above 400 arms)
High-Voltage Bus	180 V to 750 V DC (wide range of operation)
Output Voltage	Space vector modulated PWM
Parasitic Current	Off-state low voltage battery drain < 900 uA
Protection	Over-current, under-voltage, over-voltage, brake chopper with variable voltage set point, short-circuit, reverse-polarity (battery), over-temperature (motor and inverter), over-speed
PWM Frequency	1 kHz to 9 kHz
Bus Interface	CAN (two ports)
Hardware Interface	Digital/analog motor position, sensor supply (5 V or 12 V) output, motor temp sensor, eight digital spare inputs, two analog spare inputs, two digital spare outputs, four analog spare outputs, wake-up, controlled power-down
Low-Voltage Power	12 V or 24 VDC Systems (wide range of operation 9 V to 32 V)
Position Sensor	Resolver
Control Modes	Torque, speed, voltage
Operating Temperature	Coolant -40°C to 70°C, ambient -40°C to 70°C

Block Diagram

